



**CLEARANCE
BIKES**

**BICYCLE OWNER'S
GUIDE TO ASSEMBLY
AND MAINTENANCE.**

PLEASE READ CAREFULLY BEFORE RIDING

STOCKING HUNDREDS OF BRANDS INCLUDING...

AMPERE

GT
BICYCLES

THE ELECTRIC BIKE

 **OXFORD**

SALCANO

 **RALEIGH**

ammaco

SHIMANO

SRAM

 **WELDTITE**

WISPER

PROFESSIONAL

ABOUT THIS MANUAL

This instruction manual has been produced in a manner that will enable you to obtain maximum pleasure from riding your bike, safely and comfortably.

The manual advises on safety tips, explains technical points, and gives clear instructions for the maintenance and adjustment of the various parts and systems.

NEED HELP?

We recommend heading to your local Cycle King & Hawk Cycles' store for expert servicing and repairs.

[Click to Find a Store](#)



CONTENTS

ASSEMBLY 4-9

RIDING 10-12

MAINTENANCE 13-17

BASIC ADJUSTMENTS 18-35

SPECIALIST BIKES 36-40

GUARANTEE 41

These instructions are for the current ISO 4210 standards. This standard covers all variations of bicycles supplied by the PCM group.

Note: Bicycles made to ISO City + Trekking standard are not intended for serious off-road use such as rough terrain, mountain trails or tracks where rocks or similar hazards may be encountered. The bike, therefore, is not designed or intended for such conditions and incorrect use can result in mechanical failures.

If your cycle was supplied in a box for home assembly, please read through the manual carefully. Some of the following also applies to bikes purchased and assembled.

If referring to "tools supplied", there may be a couple of basic tools included with the bike, but a set of metric spanners and Allen keys, plus screwdrivers and a socket set are recommended to complete the job and maintain your cycle.

Some parts of the bike are factory fitted (pedal cranks for example), but these still need checking to ensure they are fully secure and will need checking periodically to ensure that they stay tight.

Please also pay attention to page 20 (pedals). These must be fully tightened when fitted, otherwise, they will unwind and cause irreparable damage to the cranks (these must also be checked regularly)



KNOW YOUR BIKE



QUICK BIKE ASSEMBLY GUIDE

Adult's Bike	Usage for which each type of bike is designed	Permissible total weight of rider + luggage
BS: EN 13764 Trekking Bikes	On roads and tracks	120 Kg (19 stone)
BS: EN 14766 Mountain Bikes	Off road, road/track and rough terrain.	120 Kg (19 stone)
BS: EN 14781 Racing Bikes	High speed riding. Not for off road/rough terrain.	120 Kg (19 stone)
BS: EN 16054 BMX Bikes	Cycle tracks/ramps or on road. Not for use in competition events.	120 Kg (19 stone)



UNPACKING YOUR BIKE

Take care not to scratch the bike or slash the tyres. We suggest you keep hold of the packaging in case you need to return the bike.



SUPPLIED WITH YOUR BIKE*

Allen key(s), multi-spanner, pedals and reflectors *where applicable.

PREPARING YOUR BIKE FOR ASSEMBLY

To ensure your bike is prepared for the road, please follow the instructions below. (If your bike is supplied in a carton, please refer to additional information 'on pages 18-35 for basic adjustments'. If your cycle is supplied and assembled, tools may not be provided.

Tools: Use spanners supplied.



1. Chain wheel set

2. Front gear mechanism

3. Rear gear mechanism

4. Handlebar stem

5. Seat Post

6. Multiple sprockets

7. Top tube

8. Seat tub

9. Down tube

10. Suspension fork

11. V-Style brake

12. Disc brake

13. Rear Suspension unit

14. Chain wheel set axle bolt



WARNING

Do not raise the handlebar stem past the maximum extension point clearly marked on the stem - it will be unsafe.

SAFE RIDING TIPS

- Always wear a protective cycling helmet: The minimum legal requirement for any helmet sold in the UK and the rest of Europe is that they are CE certified and conform to the EN1078 European standard.
 - ⚠ Warning: Once a helmet has been in an accident, it must be replaced. The shell may have been weakened and the liner will be less able to absorb shocks. Remember that some manufacturers offer free replacement of crash damaged helmets.
- Always select a gear that enables you to pedal at about seventy revolutions a minute (similar to your resting heartbeat). This will give you better control of your bicycle and make it easier to accelerate as you cycle along. Remember, with the correct use of the gearing system, cycling is five times more efficient than walking!
- Familiarise yourself with, and observe the cycling regulations and advice given in the Highway Code, and for general advice on cycling refer to the website: www.highwaycodeuk.co.uk/rules-for-cyclists
- Make sure that none of your clothing can be caught in the wheels or chain drive.
- Always ride defensively, be on your guard, and continually be expecting problems and hazards to occur.
- Obey all traffic regulations and local bylaws and rules.
- Use cycle lanes whenever possible.
- Regularly glance over your shoulder to observe traffic approaching you from the rear, and always do so before giving a hand signal. Give other road users clear hand signals in good time, to advise them of your intended action.
- Be alert to cars pulling out into your path, and doors on parked cars being opened in your path.
- Observe the road surface ahead avoiding potholes and drains.
- Never carry a passenger.
- Never hold onto a moving vehicle, or a stationary vehicle when stopped in traffic.
- Always ride in single file and do not ride too close to another vehicle (bikes included).

BMX ASSEMBLY CHECKLIST

- Turn the bar through 90 degrees. Align and tighten Bolt A.
- To adjust brakes: Adjustment is affected by turning the lever mounted adjusters marked C, after having fitted cable as instructed in the service manual.
- To fit pedals: Note that pedals have right and left-hand threads. Using tools supplied make sure both pedals are fully tightened. See recommended torque figures.
- Tyres: Inflate to pressure as instructed on sidewall of tyre, with a manual inflater. **DO NOT** use compressed air from a Filling Station.
- To position saddle height:
 - ⚠ **Warning: Insert seat post into frame, do not let the seat post out past the minimum insertion mark - it will be unsafe. Tighten with tools supplied.**
- Axle pegs: Screw peg on by hand and tighten to torque settings - as wheel nuts.

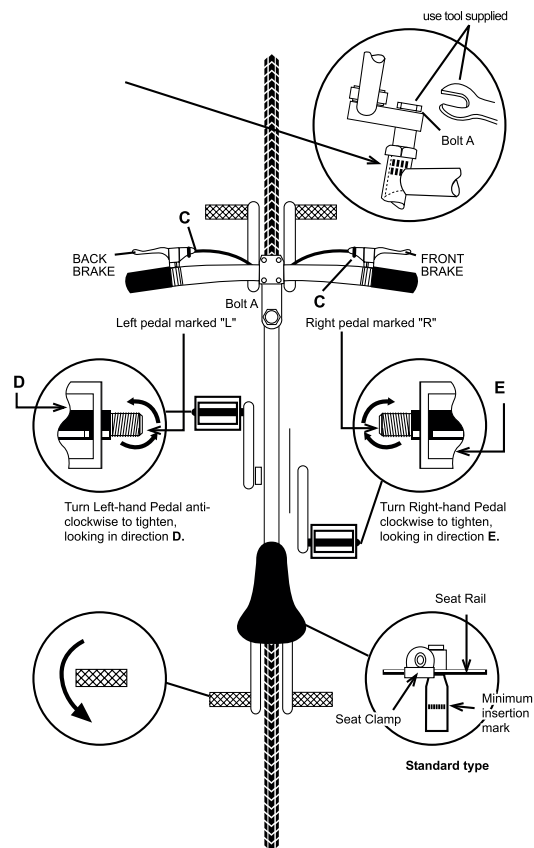

ASSEMBLY CHECKLIST

Excluding
BMX bikes,
see page 8

- To position handlebars: Insert stem into frame. Align and tighten Bolt A. Slacken Bolt B to rotate the handlebar to preferred position and tighten using tools supplied, after securing firmly press plastics covering cap into stem top (bulge stem only).
- To adjust brakes: Adjustment is affected by turning the lever mounted adjusters marked C, after having fitted cable as instructed in the service manual.
- To fit pedals: Note that pedals have right and left-hand threads. Using tools supplied make sure both pedals are fully tightened. See recommended torque figures.
- Tyres: Inflate to pressure as instructed on sidewall of tyre, with a manual inflater. **DO NOT** use compressed air from a Filling Station.
- To position saddle height:
 - ⚠ **Warning: Insert seat post into frame, do not let the seat post out past the minimum insertion mark - it will be unsafe. Tighten with tools supplied.**

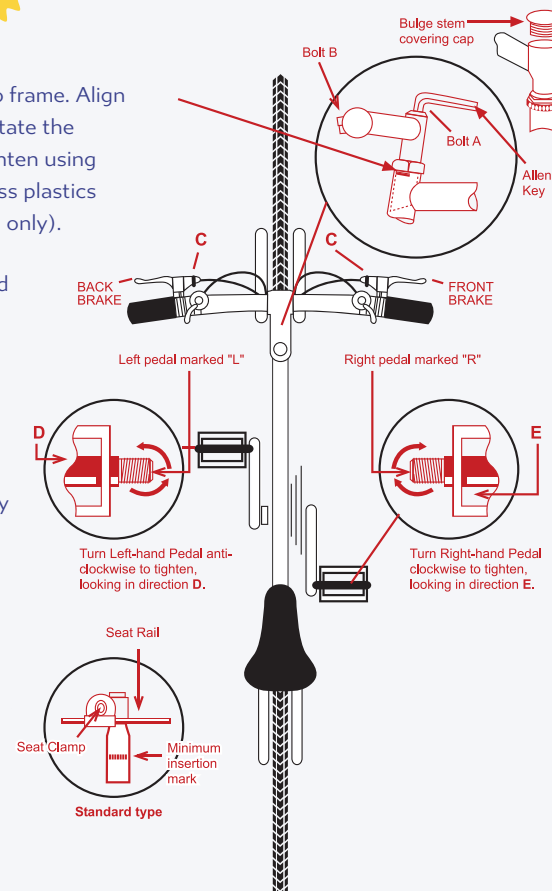

REMEMBER

- Check and re-tighten all bolts after the first few weeks of cycling.
- Your bike is a machine which you take on the road.
- Please keep it in good order and be safe.
- Always oil all moving parts sparingly, but regularly, particularly
- Do not ride with your tyres under-inflated or you may crack the tyre wall and/or damage the wheel rim.

FOR FURTHER INFORMATION AND
TORQUE SETTINGS, PLEASE SEE PAGE 13



RIDING CONDITIONS



CYCLING AT NIGHT

Minimise the time spent cycling in the dark.

Should you need to do so, the law requires that your bicycle is fitted with the front and rear reflectors and two-wheel reflectors supplied, and in addition front and rear lights which comply with BS6102 part 2.

It is recommended that light-coloured, preferably reflective garments are worn when riding in the dark.

Extra caution is required when riding in wet or icy conditions. Your braking performance will be affected by the water on the brake surfaces and between the tyres and road surface.

Stopping distances may well be doubled or even trebled, so greater anticipation of stopping or slowing is required.

Make sure you can see and be seen. Front and rear lights, a rear reflector, pedal and wheel reflectors are legal requirements. They should conform to British Standard BS 6102. Carry spare bulbs and batteries if needed. Light coloured and reflective clothing will help you to be seen.



BIKE SERVICING & REPAIRS

There is a risk of injury to the rider and others if all necessary repairs and adjustments are not made.

Ensure you can use gears and brakes effectively and that you can handle your bicycle safely in traffic.



RIDING IN BAD WEATHER

Wear warm waterproof clothing in bright, reflective colours if possible.

Sudden braking could lead to skidding on hazards such as mud, gravel, snow etc. Be prepared to walk your bike around roundabouts and difficult right turns.



EXPERIENCE

The most important general riding skills that you need to develop are keeping track of what other road users are doing and working out what they are going to do next. Make use of "cycle lanes" where they are provided.

Parents are urged not to let their children onto busy roads until they are experienced cyclists. We recommend a training course such as the Royal Society for the Prevention of Accidents (ROSPA), the National Cycling Proficiency Scheme (for children of nine and above) or the in-school version 'cycleway' for young children.

Safe Braking Distances Bicycle travelling at approx 15 mph

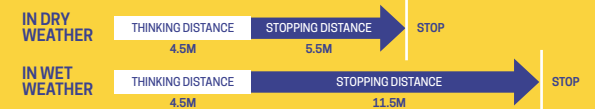



RIDING WITH JUNIORS

Riding position: They should be set up like an adult bike, with the ball of the foot just reaching the ground when the rider is sitting in the saddle.

Some smaller bikes are very different from adult machines. The chain set is particularly different because both the cranks and the axle are all made in one piece. And this is only made possible by using a very different type of bottom bracket. For work on the steering bearings, bottom bracket or chain set, see your retailer.

Find your nearest retailer here:
www.cycleking.co.uk/shops

Take care when using a child seat to make sure your child's hands and feet cannot be trapped by any moving parts of the cycle such as saddle springs, wheel spokes and brakes.

When accompanying children, insist that they ride in front of you so that you can see and control everything that is happening. Be ready to jump off your bike and intervene if it ever becomes necessary.

Check that the rider can easily get off the saddle and place their feet on the ground. There should also be sufficient clearance over the top tube when doing this.

Children should wear a cycling helmet at all times when riding their bikes.

Make sure also that they know how to use the gears and brakes. Remind them that the gears will get bent if the bike is dropped on the pavement.

Important: Child seats are not designed for use with suspension bikes. Mounting clamps should be located on the frame seat tube and must not be fitted on the seat post.



TORQUE WRENCH SETTINGS

Child's Bike	lbf-ins	Nm
Front wheel nut (5/16")	195-200	22-22.5

Adult's Bike	lbf-ins	Nm
Front/rear wheel nut (3/8" or 10mm)	220-225	24.8-25.4
Seat bolt	220-225	24.8-25.4
Seat bolt - recessed type	100-105	11.3-11.7
Handlebar expander bolt	140-145	15.9-16.4
Handlebar / seat clamp bolt	100-120	11.3-13.5
Handlebar to stem bolt (including 4 bolt)	150-155	17-17.5
Saddle Clip to seat pin	150-155	17-17.5
Saddle Clamp - allen bolt type	80-85	9-9.6
Cotterless crank main axle	420	47.5
Bolt nut	420	47.5
Suspension shock unit / Frame pivots	150-200	17.5-22.5
Pedal to crank arm	309-328	35-37

BIKE MAINTENANCE ESSENTIALS

REGULAR CHECKS

- Wheels are tightly secured and inflated to correct pressure (indicated on side-wall tyre).
- Check their condition for cuts etc.
- It's a good idea to carry a puncture repair kit or spare inner tube, tyre levers and pump with you.
- Handlebar, stem and headset locknut are tight and the steering turns smoothly.
- Gears operate correctly
- Wheels are running true by spinning them.
- You can also check that mudguards if fitted, are correctly adjusted at this time.
- Saddle is adjusted to the correct riding position and the seat pin is tightened.

⚠ WARNING: REGULAR CHECKS AND SERVICING ARE VITAL TO MAINTAINING YOUR BIKE'S UPKEEP AND RIDER SAFETY.

BRAKES

- Squeeze levers to ensure sufficient pressure can be applied without the lever touching the handlebars.
- Ensure brake blocks are aligned correctly with rim and the blocks are not badly worn.
- Brake cables are not frayed at the end.

YEARLY MAINTENANCE

- Carry out regular cleaning and degreasing.
- Use spring washers to prevent the frame mounting screws coming loose.

WARRANTY

- To rectify a problem whilst covered under warranty, contact your local dealer. For more information on what is covered under warranty, head to cycleking.co.uk/maintenance

BIKE SECURITY, SPARE AND STORAGE

- Refer to your supplying dealer for advice on security and obtaining spare parts suitable for your model of bike.
- When storing your bike, ensure you have wiped off all grease from rims and brake blocks

CHAIN ADJUSTMENT

- Check the chain tension once a month.
- When grasped in the middle of the chain run between the chain wheel and freewheel, there should be from 6mm to 12mm vertical movement.
- To adjust tension, slacken wheel nuts, pull back wheel, then retighten nuts to recommended torque checking that the wheel is centred between the chain stays.

Failure to make correct adjustments may result in damage to the bike or a serious accident. For more detailed information visit your local Cycle King or Hawk Cycles bike shop.

CLOTHING, ACCESSORIES AND ESSENTIAL BIKE TOOLS

- Waterproof reflective clothing
- Toe Clips
- LED bike lights

CLEANING

- You must ensure regular cleaning of your bike throughout the year.
- Frequent washing will help to minimise energy wasted through unnecessary friction.
- For more information on cleaning, degreasing and lubricating your bike, head to page 16.

FITTING MUDGUARDS

- Badly fitted mudguards are a major safety hazard, so ensure they are securely fitted.
- Use spring washers to prevent the frame mounting screws coming loose.

Cycle maintenance requires time, specialised skills and equipment, and for this reason, we recommend your cycle is fully serviced by your Cycle Dealer at least once a year or more often if subjected to heavy use.

REGULAR CLEANING:

To keep your cycle running smoothly, all moving parts must be free from dirt. Use warm soapy water on alloy, chrome or enamel parts. Always rinse with clean water and dry with a cloth, and then wipe chrome with a lightly oiled cloth. Keep the chain, derailleurs and rear sprockets clean by wiping down regularly with a rag. You may find an old toothbrush useful to remove stubborn grit and grime.

For more information, check out our 'cleaning your bicycle' blog here... cycleking.co.uk/content/how-to-clean-your-bike-after-a-wet-and-muddy-ride

! NEVER use a pressure washer on your bike or put it through a car wash.

LUBRICATION:

Keep your cycle in good condition by oiling and greasing regularly. As the greasing of bearings requires di-assembly and the use of special tools, we recommend that you leave this task to your dealer. You must have all bearings greased once a year.

Note: Avoid vegetable-based oil and over lubricating, as this will collect dirt and grit. Please refer to your dealer for more advice on recommended lubricants.

! WARNING - Keep all oil and grease off the rims, brake blocks and tyres.

CHAIN ADJUSTMENT:

Single-speed chain tensioning

Check the chain tension once a month, when grasped in the middle of the chain run between the chainwheel and freewheel, there should be from 6mm to 12mm vertical movement. To adjust tension, slacken wheel nuts, pull the back wheel, then retighten nuts to the recommended torque, checking that the wheel is centred between the chainstays.



Note: Chain tension- derailleur gears- The chain is automatically tensioned by the rear derailleur.

SPARES:

Spare parts such as brake blocks, disc brake and friction pads, cables, bulbs, tyres and tubes, etc; can be obtained from your supplying dealer, or any good bike shop, who will advise on the suitability for your model of bicycle. All safety-critical parts should only be replaced with genuine manufacturers parts. If your cycle has been fitted with an accessory, please refer to the packaging for instructions on use and maintenance.

WARRANTY:

Dealing with a cycle issue covered under warranty: In the first instance, refer back to the retailer you purchased the bike from. Search your local dealer's contact details here... cycleking.co.uk/shops

TORQUE WRENCH SETTINGS:

We recommend the use of a torque wrench, whenever working on your bike. This will ensure that all nuts and bolts are tightened using the correct amount of force, so preventing damage to the components.

RECOMMENDED TORQUE FIGURES:

Child's Bike	lbf-ins	Nm
Front wheel nut (5/16")	195-200	22-22.5
Adult Bike	lbf-ins	Nm
Front/rear wheel nut (3/8" or 10mm)	220-225	24.8-25.4
Seat bolt	220-225	24.8-25.4
Seat bolt - recessed type	100-105	11.3-11.7
Handlebar expander bolt	140-145	15.9-16.4
Handlebar / seat clamp bolt	100-120	11.3-13.5
Handlebar to stem bolt (including 4 bolt)	150-155	17-17.5
Saddle clip to seat pin	150-155	17-17.5
Saddle clamp - allen bolt type	80-85	9-9.6
Cotterless crank main axle bolt nut	420	47.5
Suspension shock unit / frame pivots	150-200	17.5-22.5
Pedal to crank arm	309-328	35-37

FITTING MUDGUARDS:

! Warning - Badly fitted mudguards are a major safety hazard if they get entangled with the wheel.

As for luggage straps and bungees, don't let them hang down where they could jam in the wheel.

TYRES AND TYRE CARE:

Punctures can be caused by not keeping the tyres pumped up enough, badly worn tyres, tubes that have been repaired too often or picking up thorns when riding.

Always remember to inflate tyres to the pressure indicated on the sidewall of the tyre and repair any slow punctures.



- Use Slime tyre sealant to solve punctures.
- Replace worn tyres.

Tyre levers are only intended to aid removal of the tyre. You should only use your hands to roll the tyre back on, as using tyre levers to re-fit will often result in pinching the inner tube.

- Use Skabs glueless patches and always prepare the surface of the tube with the abrasive paper supplied, before applying the patch to the tube.

BIKE STORAGE:

! Warning- Wipe off all grease before using or storing. Ensure that rims and brake blocks are free from grease.

- When storing your bike for an extended period, storing it upside down will protect the tyres.
- Smear chrome parts with grease to protect. However, take care to keep grease off plastic parts.

BIKE SECURITY:

Each year, thousands of bicycles are stolen and most are never recovered, and insurance cover may well be invalid if your cycle is not securely locked. Refer to your supplying dealer for advice on security.

- Leave in well-lit areas and take removable items with you.
- Use a lock that resists bolt cutters.
- Secure to a stationary object.

CLOTHING AND ACCESSORIES:

- Wear light trainers to fit in the toe clips and traditional style tight stretch fabric clothing.
- Waterproofs that allow sweat out without letting water in.
- Always carry a puncture outfit, a spare tube and a few basic tools in a handy bag.
- All year round, good cycling gloves will be handy, keeping your hands clean and protecting them whilst riding.
- Gel padding at the palms can help absorb road shocks. Padded shorts and leggings are one solution but underliners do the same sort of job and can be worn under leisure clothing.

ESSENTIAL BIKE TOOLS:

- Hex key multi-tool or Allen key fittings to tighten handlebars, stems and seat posts.
- Screwdrivers can be used for derailleur system adjustments and brakes.
- Pump and puncture repair kit.
- A chain splitter will allow you to sort broken links, and to fit and shorten new chains, cassette and freewheel removers are used to replace these items as they wear, and are required if spokes need replacing in the rear wheel. A spoke key is a useful tool for keeping your wheels spinning true.

This section gives instructions on the way that the various systems built into the bicycle can be adjusted and reset. For further guidance, please consult your supplying dealer.

HANDLEBAR ASSEMBLY:

Two types of handlebar stems are used:



- Standard: Held in place with a centre bolt, and adjustable height up to the level of the 'minimum insertion' mark on the vertical tube of the stem.



- "A-head" type whose height cannot be adjusted. It has a centre bolt and either one of two bolts on the side adjacent to the centre bolt. It is lighter by design than the standard type and combines the functions of setting the headset (steering) bearing tightness, and clamping the handlebars to the forks.

STANDARD ASSEMBLY:

To adjust the height or alignment of the handlebars, slacken off the bolt in the centre of the stem with an Allen key, if necessary, tap the bolt gently and it will slide into the stem, slackening the assembly. The handlebar height can then be adjusted up to the "minimum insertion" mark on the stem.

- ⚠ WARNING -** The "minimum insertion" mark must never be visible. The mark indicates the highest position to when the stem may be raised. Retighten the stem, ensuring that the handlebars are set at a 90-degree angle to the front wheel. Please refer to recommended torque figures.

"A-HEAD" TYPE ASSEMBLY:

On no account should an attempt be made to alter the height of this type of handlebar stem. Any attempt to raise the handlebars will loosen the steering bearings and render the cycle unsafe.

To adjust the alignment of the handlebars, slacken off the one/two bolts on the side of the stem, adjust the position then re-tighten. Please refer to recommended torque figures.

HANDLEBAR POSITION:



As a general guide, the top surface of the brake levers should follow the line from your shoulder to your hand.

With either system, to rotate the handlebars to obtain a more comfortable riding position, slacken off the one/two bolts, which clamp the handlebars to the stem, and re-position, re-tighten the clamping bolts ensuring that with the two-bolt clamp, the two bolts are tightened equally. Please refer to recommended torque figures.

ROTOR CABLE INSTALLATION AND ADJUSTMENT

Refer to illustration. Cable installation and adjustment should only be done by a qualified mechanic.



UPPER CABLE:

1. First, connect the barrel end of the upper cable to the rear brake lever.
2. Route the upper cable through the handlebars (below the crossbar) with the short cable casing on the same side as the rear brake lever. This allows the upper cable to be shorter and less intrusive.
3. Connect the upper cable to the upper plate by passing the football ends of the upper cable through the threaded holes in the upper plate and connecting them to the ory bearing.
4. Screw the adjusting barrels into the upper plate. Don't tighten the locknuts at this time.

LOWER CABLE:

1. Slide the single cable casing through the cable guide on the frame.
2. Connect the lower cable to the lower plate by passing the football ends of the lower cable through threaded holes in the lower plate and connecting them to the ory bearing.
3. Screw the adjusting barrels into the lower plate. Don't tighten the locknuts at this time.
4. If necessary, measure and cut the single cable casing to the correct length of your bike.
5. Connect the lower cable to the rear bike. Don't adjust the rear brake at this time.

Note: Check to make sure all II-cable casing ends on the upper and lower cables are seated correctly and that the spring tension of the rear brake is pulling the ory bearing down.

ADJUSTMENT:

1. Screw the adjuster on the brake lever and the cable adjuster located in the cable splitter of the upper, cable all the way in.
2. Set the bearing position for the maximum travel with the adjusting barrels in the upper plate. Screw them in (or out) until the bearing is as far down as it can go without resting on the lower plate or the adjusting barrels screwed into the lower plate.
3. Use the adjusting barrels that are screwed into the upper plate to make the bearing parallel to the upper plate. Use a wrench to tighten the locknut on the left adjusting barrel of the upper cable. Leave the right one loose.
4. Screw the adjusting barrels on the lower cable into (or out of) the lower plate until they are as close to the bearing as they can get without touching the bearing.

5. Screw the cable adjuster, located on the cable's splitter of the upper cable out until all the slack is removed to form the upper cable. Now screw the adjusting barrel out one more turn to raise the bearing an additional 1mm (1/32") away from the lower plate.
6. Check that the bearing flop by placing the handlebars in the normal riding position, then quickly rotating the handlebars back and forth (about 1/8th turn). Perform the following steps to eliminate bearing flop.
7. Finish adjusting the rear brakes.

- ⚠ CAUTION:** Don't screw the cable adjuster located on the cable splitter of the upper cable out more than 8mm. If more adjustment is needed, use the cable adjuster that is screwed into the rear brake lever.

Note: The ory bearing should never be allowed to rest on the lower plate or the adjusting barrels screwed into the lower plate.

- a. Screw the adjusting barrels on the lower cable or (on into) the lower plate until the bearing flop is eliminated (checking bearing flop as described in step 6).
- b. Tighten the locknut on the left adjusting barrel on the lower cable.
- c. Rotate the handlebars 180 degrees and recheck for bearing flop. If there is any bearing flop, use the loose adjusting barrels on the upper cables to remove it.
- d. Repeat steps a, and c until the handlebars can be rotated 360degrees without any bearing flop.
- e. Tighten the loose locknuts and recheck for bearing flop by rotating the handlebars 360 degrees.

FRAME AND FORK ADJUSTMENT

FRAME:

The full suspension frame is fitted with a pivot which allows the rear end of the frame to move as the suspension unit is compressed under load. Checking the tightness of this pivot should be included in the regular checks on your bike, but any further maintenance should be carried out by your dealer.

The rear shock absorber unit which is compressed under load can be adjusted to accommodate riders of different body weights and also to give either a soft or hard ride. The total adjustment available on the unit is between 25-28mm. As a starting point, the unit should be adjusted by turning the large knurled collar from a position where it does not apply any load on the spring, sufficient to compress the spring about 8mm. To give a harder ride, turn the collar to compress the spring further. In the same manner, to achieve a softer ride, slacken off the spring compression.

FORKS BASIC:

Basic suspension forks cannot be adjusted, but for a long reliable life, ensure that the foam or bellow type gaiter at the top of the forks remains in good condition, with the chrome tube regularly wiped with an oily cloth. The purpose of the gaiter is to prevent the ingress of grit and dirt into the sliding tubes of the suspension units. For adjustable forks, refer to your supplying dealer for information on maintenance and adjustment. Images

BOTTOM BRACKET SPINDLE AND CHAINWHEEL

Check for play by holding crank arms and pushing/pulling. Any excessive movement of the bottom bracket assembly should be referred to your supplying dealer.

CHECK PEDALS

Regular checks on the tightness of the pedal fit into the cranks should be carried out. It will be noted that the right-hand pedal is marked with a letter "R" on the spindle end, indicating that it has a right-hand thread and must be screwed in and tightened in a clockwise direction.

Turn left-hand pedal anti-clockwise to tighten, looking in direction A.

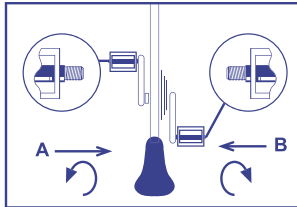

Turn right-hand pedal clockwise to tighten, looking in direction B.

The left-hand pedal is marked with an "L" and should be tightened in an anti-clockwise direction. Please refer to recommended torque figures.

⚠ Warning- Always keep the pedals tight onto the cranks- they will need checking regularly to ensure that they stay tight.

WHEELS

Safe cycling depends a lot on the condition of the bicycle wheels. Tyres should be inspected to check that no damage has been caused to the tread or side wall. The tyre pressure should be checked weekly to keep the pressure at the value given on the tyre wall. Should the tyre require inflating, it must be done using either a hand or foot pump to a pressure no greater than that shown on the side wall. Recommended pumps can be obtained from your supplying dealer.

On no account should the tyres be inflated using a garage forecourt pump or compressor.

WHEEL RIMS:

On some rims, a wear indicator line is shown on the side, this line should be checked regularly. Should a break in the line become apparent or if the rim is damaged, replace it immediately.

QUICK-RELEASE WHEELS

Before operating the quick release, open up the distance between the brake pads so that the tyre doesn't get stuck between them. To do this on V-style brakes, press the brake pads onto the rim with one hand while you pull the metal cable pipe away from the brake arm with the other. With other cantilevers, you also squeeze the brake pads together but then you slip the end of the short cable out of the brake arm.

If you're not sure that you've refitted the wheels correctly, or wonder if you've got them tight enough, consult your retailer.

VALVE TYPES: "SCHRADER" TYPE AND "PRESTA" TYPE



FRONT WHEEL REMOVAL:

Disengage the brake cable guide tube from its yoke, to allow the brake blocks to move clear of the rims and tyre. Loosen off the two-wheel nuts sufficient to clear the safety nut retainers in the fork-end. Allow the wheel to fall clear of the forks.

TO REPLACE THE WHEEL:

- Reverse the above procedure, checking that the wheel is centred in the forks before tightening (refer to the recommended torque figures).
- If your bicycle is fitted with 'quick release' wheels, pull the QR lever away from the forks to 'open' (the lever is usually marked open/closed). Slacken off the knurled nut on the opposite end of the quick-release fitting until the wheel falls clear of the forks.
- To replace the wheel, reverse the above procedure, and with the QR fitting on the left side of the forks when looking to the front, tighten the knurled nut until the lever can only be moved to a position 30 degrees above the horizontal.
- Check that the wheel is central in the forks. Push the lever upwards to a position in front of, and next to the fork blade. (The lever usually shows an indication for open/closed). Re-arrange the brake guide tube in its yoke and check that the brake functions correctly.

Quick release hub

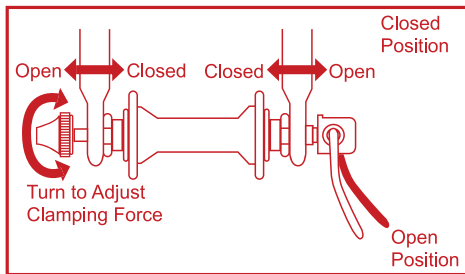
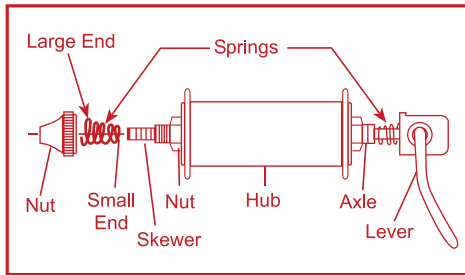

Warning: Riding with an incorrectly adjusted wheel quick release can damage your bicycle and cause personal injury. Before each ride check quick release mechanisms to ensure wheels are securely fitted.

The axle on a quick release hub is not only hollow but is much shorter than a normal axle that is fitted with nuts. This means the axle ends do not protrude from the fork drop outs. Running through the axle is a skewer (long thin bolt) with a lever mechanism at one end and a conical nut at the other. Additionally, two conical springs are fitted one on each side as shown in the diagram.

With the skewer, springs and conical nut fitted to the axle, ensure the lever is in the open position. Fit the front wheel into the forks and with the lever held in one hand turn the nut until it just touches the dropout. In this position close the lever. If this can be easily accomplished, open the lever and re-tighten the nut. However, if the lever cannot be fully closed then open the lever and loosen the nut half a turn.

When closing the lever with the palm of the hand, sufficient force must be used so that an imprint of the lever is left in the skin.

REMOVAL:

Before refitting the tyre, or replacing the tyre, it is recommended that you can run your hand slowly and carefully around the inside of the tyre to check that no objects are protruding through the tyre casing.

- To re-fit the tyre, insert one side of the rim into the tyre and push that one side onto the rim around its full circumference.
- Pump two or three times into the deflated inner tube, then insert the valve through the valve hole in the rim ensuring that the rim tape does not prevent the valve from being pushed fully into the valve hole.
- Push the inner-tube fully into the tyre right around the rim then with the valve positioned at ground level, start pushing the second side of the tyre onto the rim from the top. When the tyre starts to tighten across the rim, return to the starting point at the top, directly opposite to the valve, and repeat the removal operation of squeezing, and at the same time pushing the tyre to the bottom. The effect will be to slacken the tyre at the bottom and in most cases will enable the tyre to be fully fitted without the use of tyre levers.
- Should this not be possible again, use a tyre lever, taking care not to trap the inner tube between the rim and the lever, as this could punch the tube causing another hole! When fully fitted, run both hands around the tyre, squeezing it away from the rim.
- Inflate to one-third hard then again run your hands around the tyre, squeezing it away from the rim, to ensure that the innertube has not been trapped between the rim and the tyre. If it is not trapped, complete its inflation to no greater than the pressure recommended on the tyre wall.

Note: When removing and re-fitting the rear tyre, do so from the side opposite to the sprockets to prevent oil from coming into contact with the tyre or tube.

TYRE REMOVAL AND RE-FITTING:

- First remove the wheel from the bicycle, if the tyre is not fully deflated, remove the valve dust cap and push in the valve centre to release any remaining air (Schraeder valve). With Presta valves, first, unscrew the small locking nut, then press the centre holding the wheel on the ground with the valve at the top, squeeze and push the tyre down each side to the bottom of the rim.
- In most cases, it will now be possible to flick the tyre off the rim by hand without using a tyre lever. Should you be unable to do this, using a tyre lever pushed between the tyre and the rim, lever off the tyre taking care not to nip the inner tube between the lever and the rim



REAR WHEEL REMOVAL:

Rotate the chainwheel and the rear gear so that the chain is on the smallest sprocket. Disengage the brake, as described in front wheel removal, then slacken off the two wheelnuts and allow the wheel to fall free from the dropout. To re-fit the wheel, place the chain onto the smallest sprocket; re-locate the wheel in the dropout and tighten the wheel nuts (refer to recommended torque figures) ensuring that the wheel is central to the seat and chainstays. Re-engage the brake guide tube in the yoke, checking that the brake operates correctly.

REAR WHEEL REPLACEMENT:

Ensure that the quick release mechanism is open. Take up all the tension in the derailleur spring by holding the derailleur fully back. Place the top part of the chain on the small rear sprocket and ease the wheel into the frame. Make sure that the wheel is centred in the frame if the rim is equidistant from the chainstays, and the axle is located securely in the chainstay ends. Replace the derailleur protector, if fitted. Close the quick release lever as detailed below, or tighten the axle nuts to the recommended torque.

Warning: Remember to close the brake quick release lever, or reset the cable adjuster. (Images)

WHEEL RIM CONDITION

- There are two ways of checking when a rim has come to the end of its useful life and should be changed: A "wear-line" on the outside of the rim in the form of a groove. When this groove has been worn away the rim should be changed.
- A special cavity inside the rim. The rim should be changed when this starts to appear as a slot in the sidewall. During winter, the rims can become very greasy. To maintain full braking power, clean them with an Extreme Degreaser, if the brakes don't seem to have their usual bite.



SADDLE ADJUSTMENTS AND RIDING POSITIONS:

It is important both from a safety and comfort aspect to ensure that the saddle is set to the correct position. The saddle should be level and at a height so that when seated with the pedal at its lowest position and the ball of your foot on it, your leg is not quite straight and can move forward and backwards.

Stand over height is the distance from the ground to the top of the tube at the point where your crotch would be if you were straddling the bike by standing halfway between the saddle and the handlebar stem. To check, straddle the bike. If your crotch touches the frame, the bike is too big for you. A bike you ride only on-road should offer a minimum clearance between the top tube and your crotch of one or two inches. A bike that you'll ride off-road on tracks should have three inches minimum clearance, whilst a mountain bike for use on rough terrain should offer four inches clearance.

TWO STYLES OF SEAT POST ARE USED:

- Traditional clamp type- The clamp attached to the saddle wraps around the seat post and is clamped by a bolt and a nut. Slackening the bolt allows the saddle to be adjusted in all planes. Re-tighten when the required position is established. Refer to the recommended torque figures.
- Micro-adjust- The seat post holds the saddle by the frame using an Allen bolt. This type allows a more accurate level position to be obtained and is a neater design than the traditional type. Adjustment is achieved by slackening the Allen bolt swinging the saddle to the correct position, then re-tighten the clamping bolt. Refer to recommended torque figures.

⚠ Warning: The seat must not be raised above the level of the "minimum insertion" mark, which is marked on the seat post.

- Saddle springs: If you have a child seat fitted to the rear of your cycle, you must ensure that any exposed springs under your saddle are covered to prevent the trapping of fingers.

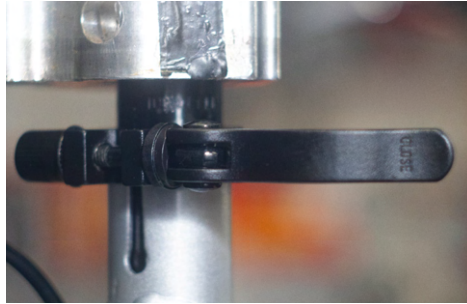

Quick release seat post clamp: A quick release seat post clamp must be tight enough to hold the seat post in place on the roughest road. So, tighten the knurled nut as far as you can with your fingers, then undo it one full turn. Next, start to move the q/r lever.

It should be easy to move at first, then harder as the lever gets nearer to the frame, then easier just before it hits the frame. Turn the knurled nut anti-clockwise if the lever is too tight to reach the frame and the other way if it's too loose.



DERAILLEUR GEARING SYSTEM

As the name suggests, the gears fitted operate by "de-railing" the chain from one chainwheel or sprocket to another. The gears may only be changed when the chainwheel is rotating. Setting up the gears involves making sure that the front and rear gear mechanisms are vertically in line with each of the sprockets or chainwheel when that gear is selected, and that the chain can't be moved past either of the outside sprockets or chainwheels. When seated on the bicycle, the

rear mechanism is operated by the right-hand lever, a dual control lever, or a twist control, and the front mechanism is operated by the left-hand lever or twist control. If you are unsure about the operation or adjustment of the gears, please refer to your supplying dealer.

Note: Should your bicycle fall over onto the gear side, check that the rear gear mechanism has not been bent inward before riding. Should this have happened, then it is highly probable that the gear will come into contact with the spoked the next time the largest sprocket is selected, resulting in an accident and serious mechanical damage.



REAR AND FRONT MECHANISM



Rotate the chainwheel and at the same time move the right-hand lever into the highest gear. This should place the chain onto the smallest sprocket. To achieve this with the dual control lever, press repeatedly the small lever mounted on the inside face of the lever.

To ensure that the cable is fully bedded into the cable stops, grasp the bare gear cable nest to either the top tube or the down tube and strongly pull away from the frame. Should any slackness develop, slacken the pinch bolt which clamps the gear cable on the gear mechanism and pull through the slack cable. Re-tighten the pinch bolt. Rotate the chainwheel again and check that the chain runs freely and smoothly on the smallest sprocket. If it does not, observe the gear from the rear to see which way the gear is out of alignment either inward or outward. Should the gear be too far inward, turn the small screw on the gear marked 'H', in an anticlockwise direction. If it is too far out, turn the screw in a clockwise direction until the gear is aligned. This operation has set the top gear limit. Similarly, after moving the gear lever into the lowest gear, set the lower gear stop by adjusting the small screw marked 'L'.

Warning: On cycles fitted with more than five gears, avoid excessive use of crossover gears where the chain runs from smallest front to smallest rear or largest front to largest rear as this will cause chain and sprocket wear and is likely to cause the chain to rub on the front mechanism.

To set the precise settings for the individual gears, rotate the chainwheel and change the chain onto the smallest sprocket, then turn the twist control, or move the lever to select the next to smallest sprocket. Continue to turn the chainwheel and at the same time, turn the knurled sleeve into which the gear cable fits on the gear mechanism in a clockwise direction until the chain can be heard to start rubbing on the third sprocket. Turn the sleeve slightly in a clockwise direction until the noise stops. The rear gear mechanism is now set and each gear on the sprocket can be selected by the movement of the twist control or the lever. To affect this setting with the dual control lever, note that the small inner lever will move the chain onto smaller sprockets, whilst pushing the "brake" lever inward will move the chain onto the larger sprockets.

FRONT MECHANISM:

To set, first check that the side plates of the cage, which surrounds the chain, is parallel with the chainwheels. If it is not, slacken the clamp on the seat tube and move to give the correct position, then re-tighten taking care not to allow the clamp to slide down the tube.

Note: The correct position of the cage is for the outer side of the cage to be 3mm above the largest chainwheel.

In a similar manner to the rear mechanism, the top and lower limit stops must first be set. Whilst rotating the chainwheel, move the rear mechanism to select the largest sprocket, then move the front mechanism to select the smallest chainwheel. The chain should be just clear of the inside face of the inner plate of the chain cage. If not, turn the screw marked 'L' in the required direction to give the correct chain position, bed in the cable as described for the rear mechanism.

Note: The dual lever control operates the same as the rear lever, small lever to move onto the small chainwheel and the large lever to move onto the large chainwheel.

On some models the twist control or lever moves to one of three positions, on others, the control operates on a ratchet. Move the control or lever moves to one of three positions, on others, the control operates on a ratchet. Move the control again to move the chain onto the largest chainwheel. Should the chain be touching the shifting cage, twist the adjuster on the control through which the cable enters the control to move the chain cage clear of the chain. Move the control fully forward to return the chain to the smallest chainwheel. Repeat the procedure with the chain on the smallest rear sprocket.

GEAR LEVELS

GRIPSHIFT

Left/Right Hand Gear Shifter



RAPIDFIRE

Left/Right Hand Gear Shifter

DUAL CONTROL

Left/Right Hand Gear Shifter



BRAKING SYSTEMS

Like all skills, braking requires practice to enable you to learn the braking capabilities of the brake system.

! Warning: On all bicycles in the UK, the right-hand brake lever operates the front brake and the left-hand lever operates the rear brake.

BRAKES:

Your cycle will be fitted with one or a combination of two of the following six types of braking systems:

- Calliper side pull brakes
- Cantilever brakes
- V-brake cantilevers
- Roller hub brakes
- Mechanical disc brakes
- Hydraulic disc brakes

In all six cases, you must keep your brakes correctly adjusted and maintained. Your bicycle should have been correctly adjusted by your dealer, however, as cables stretch, it is important to check the adjustment after your first ride. Always check your brakes before each ride for correct adjustment.

Please refer to your supplying dealer for advice on the maintenance of your braking system.



TIGHTENING BRAKES FROM THE LEVER (ALL TYPES)

Tightening the cable adjuster on the brake lever.

To tighten the cable, undo the locknut arrowed in the picture. Then undo the knurled adjuster two turns anticlockwise and test. If the brakes are ok, retighten the locknut but for the sake of safety always leave three full threads in the brake lever.



Ensure slots are not all in line to keep the cable secure. This should be checked regularly.

V BRAKES



Once the adjustment has been made, check that the blocks are equidistant from the rim and that the wheels turn freely without binding.

To centralise the wheel rim between the brake blocks, simply turn the alignment screw clockwise or anti-clockwise until the brake blocks are equidistant from each side of the rim.

For further advice on maintenance and adjustment of V brakes, please refer to your supplying dealer.

ROLLER HUB BRAKES



1. Release lock ring by turning in an anti-clockwise direction
2. Turn adjusting barrel anti-clockwise until the correct gap is achieved.
3. Tighten the lock ring down by turning clockwise.

Once adjusted, ensure that the wheel rotates freely without binding.

For further advice on maintenance/adjustment on roller/hub brakes, please refer to your supplying dealer.

CALIPER BRAKES



Minor adjustments can be made by using the barrel adjuster. By loosening the locknut and turning the adjuster, the brakes can be set just clear of the rim. You may find it easier to turn the adjuster while holding the brake blocks against the rim, to reduce cable tension. Remember to tighten the locknut after adjustment.

If all the adjustment has been taken up by the barrel adjuster, you may have to adjust the cable length. Screw the barrel adjuster to the middle position and hold the brake blocks against the rim to reduce cable tension. Then release the cable pinch bolt and pull the cable through with a pair of pliers. Tighten the pinch bolt firmly. Fine adjustments can now be made by using the barrel adjuster.

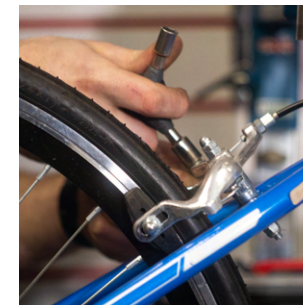

BRAKE BLOCKS (BRAKE PADS CANTILEVER/V BRAKE AND CALIPER TYPES)

Always ensure that they are free from oil/grease.

Regularly check for wear:

- Leather face- replace blocks before leather faces have worn away.
- Rubber- replace when wear is at bottom of grooved sections, or when wear line is reached.

Replacement brake spares etc should be obtained only from a bicycle dealer, to ensure correct fitting of genuine parts.

STANDARD CANTILEVER

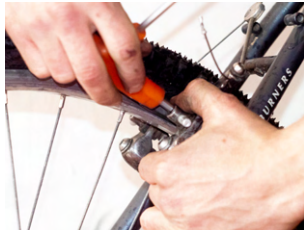

1. To fit new brake pads to standard cantilevers, slacken off the cable adjuster on the brake lever and then unhook the wire from the brake arm. Loosen the nut at the back of the pad holder, using a hexagon key to stop it from turning round and round.



2. Turn the pad clamp so that the brake pad faces away from the rim. Pull the worn pad out of the clamp and fit the new one. Align it with the rim leaving a gap at the top and set toe-in at 1mm. Check again when the pads have worn down.

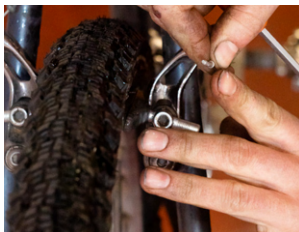

3. Check also that the angle of the brake pad brings it square onto the wheel rim. When you've checked all these points, tighten up the pad clamp nut. Make sure the pad doesn't move by holding the front of the pad clamp with a hexagon key.

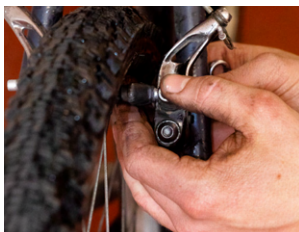

4. If a standard cantilever is not working well, check that the straddle wire lines up with the diagonal mark running across the cable carrier (arrow). If it doesn't, undo the straddle wire clamp and adjust the length of the straddle wire.

DISC BRAKES

It is better if the bike is upside down when fitting a disc brake wheel. Disc brakes, have larger pads that can easily wipe any water or mud off the disc. This gives you consistent levels of braking, whatever the weather or the surface conditions.

Disc brake pads should be replaced every 2 to 3,000 km or when they have worn down to 6.3 mm in thickness, whichever comes first.

Refer immediately to your retailer if the disc gets scored or distorted or you hear any unusual noises, especially screeching or grinding sounds. Please note disc brake type may vary from model to model, but in principle, their operation is the same.

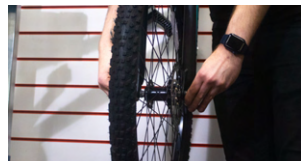

1. To remove a front wheel with a disc brake, turn the quick release lever to the open position and let it drop out. If it seems stuck, undo the adjuster nut a bit. When refitting the wheel, lift it carefully into place and re-adjust the quick release.



2. To fit a new cable, hold the back of the cable clamp with a spanner while you loosen the cable clamp with an Allen key. This is also the first step when you have to strip down the caliper to free it off or when you want to fit new brake pads.



3. To fit new brake pads, you next have to free the inner pad holder from the caliper body. So, locate all three fixing bolts and go round undoing each one half a turn at a time. This method of working will prevent any distortion of the parts.



4. When you have removed all three bolts, gently prise the pad holder away from the caliper body. The pad is held in place with a tiny spring, so prise this away as well. Be very careful, as the spring can fly in any direction



5. You can now shake the pad out of the holder. Check the thickness of the pad to see if it needs replacing and clean any dust out of the pad holder and caliper body. You must not inhale the dust, so use multilube for this part of the job.



6. Fit the new pads into the pad holder and caliper body, holding them there with the springs. However, they don't hold the pads in place very firmly and the pins on the pad holder are a tight fit for the holes in the caliper body, so be careful.



7. When properly located, the pad holder is a snug fit on the face of the caliper body and there should be an even gap all the way around. Re-fit all three Allen screws next, going around tightening them a quarter or a half turn at a time.



8. The caliper body is held onto the fork leg by two pins but it must be easily moveable. If it seems to be fixed, strip the caliper down again and take care to fit it all back together again evenly. Finally, adjust the brake pads.

ADJUSTING BRAKE PADS:

You need an 8 mm ring spanner and a 2.5 mm hexagon key for this job, which is best done with the bike upside down. Hold the central bolt still with the hexagon key while you undo the lock nut about a turn. Turn the hexagon key clockwise until the pads scrape the disc when you spin the wheel. Next, turn the hexagon key anti-clockwise half a turn so that the pads only scrape the disc very lightly. Holding the hexagon key still, you tighten the lock nut and then apply the brakes 4 or 5 times. You should still be able to hear a very light scraping but if you can't hear anything or, on the other hand, the scraping is very noticeable, try adjusting the pads again.

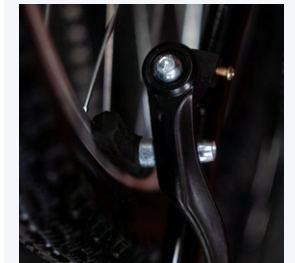

CHECKING THE CRANKS AND BOTTOM BRACKET

All the power that you generate with your legs passes through the chainset and the bottom bracket bearings, which means that the hexagon bolts holding the cranks onto the bottom bracket must be kept very tight. We recommend using a torque wrench but a long hexagon key will do.

If you ever hear a creaking noise from the bottom bracket, it may be a sign that one or another of the crank bolts need tightening.



1. To tighten up the crank bolts, grasp one crank firmly with one hand to hold the chainset still. Then apply as much force with a torque wrench or hexagon key as you can with the other. Don't forget to tighten the other crank as well.



2. When you've tightened both crank bolts, check that the thread of both crank bolt covers is lightly coated with anti-seize grease. Then tighten the covers, where fitted, with a pin spanner so they won't come out while you're riding.



3. Before you check how tight the chainring bolts are, it's worth undoing each one in turn and coating the thread with a copper-based anti-seize compound before refitting. This prevents corrosion and stops the bolts from seizing up.

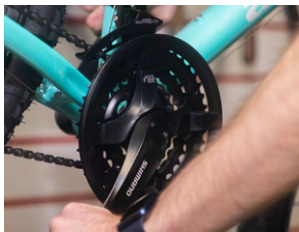

4. Check the crank bolts for tightness by holding one crank still while you try to move the other one. Test for movement from side to side as well as backwards and forwards. Then apply the test to the other crank.

CHECKING THE BOTTOM BRACKET:

To test for wear in the bottom bracket bearings, take hold of the ends of both cranks and try to rock them from side to side. If only one crank seems to move, it's loose on the axle and the crank bolts should be tightened up before you ride the bike again. On the other hand, if both cranks move sideways the same amount, the bottom bracket bearings have got some play in them. Sometimes the bearings can be adjusted to eliminate this play but if it's a modern, sealed bottom bracket, the whole thing has to be replaced. In either case, it's a job for your retailer. However, depending on how much you use your bike, it's unlikely to need doing for several years.



GEAR CHANGING

Gears fitted to the right-hand side of the handlebar control the rear gear. To help you keep track of which gear you are in, they are usually fitted with an indicator.

If a changer is fitted to the left-hand side of the handlebar, this controls the front chainwheel gears. Don't try to change gear when the bike is standing still or coasting downhill.

INDEXING ADJUSTMENT:

If gears are slow to change up to top gear or tend to jump off when you select bottom gear, try tightening the cable adjuster half a turn. If that doesn't work, try another half turn or try tightening the cable.

SHIMANO DERAILLEUR (BACK WHEEL REMOVED FOR CLARITY)

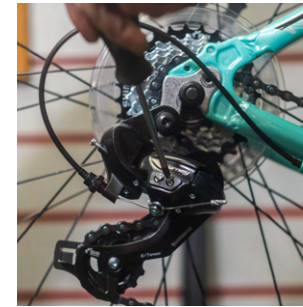

1. To set up Shimano gears correctly, let the chain down onto the smallest sprocket. Try turning the H adjuster either way until the chain runs almost silently when you turn the pedals. Then undo the H screw another half turn anti-clockwise.

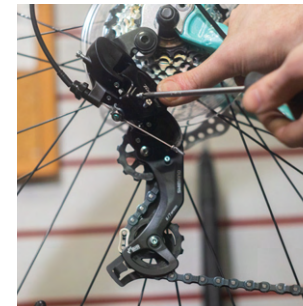

2. Next, turn the pedals slowly and use your thumb to push the gear inwards against the spring, lifting the chain up onto the big sprocket. Adjust the L screw until the chain runs almost silently, then let it jump back down onto the smallest sprocket.

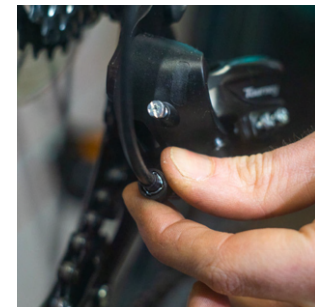

3. Test the change from the smallest sprocket to the next. It should click up and down without delay. If it doesn't, give the cable adjuster half a turn anti-clockwise. Then test the top to bottom change and adjust the L screw if necessary.

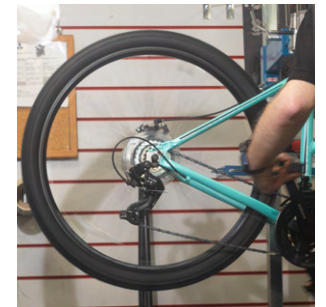

4. Keep on increasing the cable tension half a turn at a time until the top to second change works well going both ways. Finally, flick up and down the whole range of sprockets several times, as fast as you can, just to check.

SRAM DERAILLEUR:



1. Adjust the H screw so that a line through the centre of both jockey wheels hits the outer edge of the smallest sprocket. Then press the gear inwards with your thumb and adjust the L screw so that the jockey wheels line up exactly with the largest sprocket.

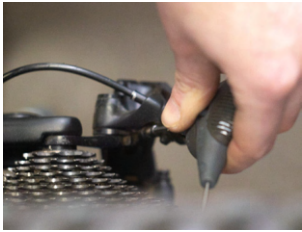

2. Now check that there are 3 chain rivets between the point where the chain leaves the biggest sprocket and where it first touches the top jockey wheel. Adjust the B screw if necessary.

FRONT CHANGER:

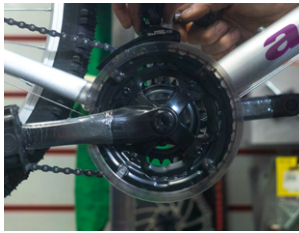

1. If the chain cage is more than 1 mm from the biggest chainring, slacken off the bolt on the clip a little. Then drop the front changer until it is as close as the indicator shown here. The outer chain cage must also be parallel with the chainring.



2. Turn the L screw clockwise if the chain tends to get thrown off the small chainring. Turn the H screw clockwise if the chain tends to come off the big chainring. Turn the adjuster screws anti-clockwise if the chain doesn't climb easily onto the chainring.

STIFF LINK BOX AND IMAGE

If you feel your gears jerk, a link in your chain may have stiffened. Clean the chain first, then turn the bike upside down and rotate the pedals. This way, you'll easily spot the link which doesn't run through the chain cage smoothly.

Flex this link from side-to-side with your thumbs, until you feel it loosen up. For more advice, visit your retailer.

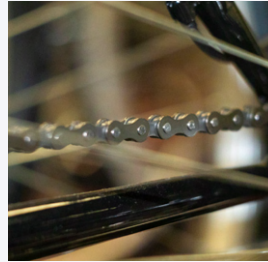

SETTING UP SUSPENSION

The objective is to adjust the strength of the springs so that when you put your weight on the saddle, the bike sinks down or sags about thirty per cent of the total spring travel. As for your riding technique, try to develop a smooth pedalling style to stop the bike bobbing around. And when climbing hills, change to a lower gear earlier than you would otherwise.

- !** Warning: If there's not enough adjustment to get the right amount of sag, talk to your retailer about fitting alternative springs.

REAR SUSPENSION:

Rear suspension sag can be reduced by turning the adjustable spring seat clockwise. Or increased by turning the spring seat anti-clockwise. Keep testing and adjusting the spring until you get the amount of sag right.



BIKE TYPE 1: SPECIALIST BIKES

Hub gear or utility bikes are nearly always designed to have an upright riding position. By carefully adjusting the handlebars, you can get some of your weight forward but not a lot.

- As for saddle height, it's best to position the saddle so that you can get the ball of your feet on the ground while sitting on the saddle, without stretching at all.
- You should pedal with the ball of your foot.
- Hub gear bikes have a different back wheel safety system, so take careful note of how the wheel nuts and washers are fitted BEFORE removing the wheel and stick rigidly to this arrangement when you replace it.



ADJUSTING A STURMEY ARCHER IMAGE

- If it slips or jumps when you're pedalling or when refitting the back wheel, turn the whole control chain clockwise. It must be screwed into the gear as far as it will go.
- If you're refitting the back wheel, screw the cable connector onto the end of the control chain until it almost reaches the knurled nut set in second gear. Then look through the hole in the sleeve nut and locate the main part of the control chain. Turn the connector until the shoulder of the control chain lines up with the end of the axle.
- Lock the connector with the knurled nut.

HUB GEAR BIKES:



1. When removing the back wheel of the hub gear bike, disconnect the control chain from the gear cable. Undo the knurled nut about an eighth of a turn anti-clockwise, then undo the cable connector about 12 turns anticlockwise.



2. Let the cable dangle while you loosen both hub nuts with a spanner. When the long sleeve nut is free, pull it off the control chain and lift off the two safety washers that fit under the hub nuts. Put the washers and nuts in a safe place.



3. To refit the wheel, wrap the chain around the sprocket and lift the wheel up into the slot in the frame. Make sure you fit one of the heavy safety washers to each side of the axle, under each hub nut with the serrated side facing inwards.



4. Pull the wheel back until the chain is taut, then tighten the wheel nuts with your fingers. The chain should have about half an inch of slack and the wheel must be centred in the frame.

Then tighten the wheel nuts half a turn at a time each.



5. Once the hub nuts are tight, check that you can only lift the chain about half an inch. And also, that the wheel is exactly in the centre of the frame. Tighten the hub nuts for the last time, reconnect the gear cable and adjust.

Note: The chain is automatically tensioned on models fitted with derailleur gears.

REAR SUSPENSION:



1. The gear change on a Shimano Nexus hub gear is made in one piece with the brake lever. Change gear by clicking up and down with the inner part of the handgrip. Nexus gears and brakes must be refilled with grease every 6 months.



2. To adjust a 7-speed Nexus hub gear if it makes an odd noise when riding normally, select 4th gear on the changer.

Then adjust the gear cable with the adjuster under the chainstay so that the two red slots (arrow) line up exactly.



3. Adjust hub brakes using the cable adjuster and then spin the wheel to check it's not dragging. If grease ever leaks out, if the gear or brakes ever make odd noises or if it needs regreasing, refer to your retailer straight away.

BIKE TYPE 2: BMX BIKES

BMX frames are built for strength rather than speed and the basic design does not vary a lot. Only one size of frame is normally available, though the saddle adjusts up and down to cater for riders of varying heights.



1. When setting up the back brakes, screw the adjuster in as far as possible. Then loosen off the straddle wire yoke and position it about half an inch from the frame and retighten. The idea is to allow the longest possible straddle wire.



2. Release one end of the straddle wire and run it around the yoke. If it won't reach, fit a new straddle cable and repeat. Refit the straddle cable to the brake arm, tension the straddle wire with pliers and then tighten the clamp bolt.



3. Now check the cable assembly just below the handlebars. Make sure that the middle plates are free to move. Adjust the brake cables so that both moving plates are an equal distance apart at their ends and level with the ground.



4. Test the tension on the top section of the rear brake cables. If they're slack, increase the tension using the cable adjuster near the brake lever. Then test the back brake, tightening the cable using the adjuster on the frame if necessary.

BMX HANDLEBAR ASSEMBLY INSTRUCTIONS

1. Slacken bolt A, whilst supporting the handlebar stem to permit the stem to be turned to the correct forward-pointing position without damaging the rear brake cables.
2. When in the correct forward-pointing position, set the stem below the minimum insertion mark. Retighten bolt 'A' firmly with the spanner supplied.
3. Slacken the four clamping bolts to permit the handle-bars to be upward to the desired riding position.
4. The handlebars are secured onto the stem using four Allen bolts. All four bolts must be tightened by the same amount. Diagram 1 shows the stem and the four bolts locking from the top and indicate the order in which they should be tightened.
5. The bolts should be tightened one full turn at a time so that the gap between the top plate and the stem body is equal around the stem (see diagram 2). The bolts should all be tightened securely using the Allen key supplied to the tightening torque given in the manual.

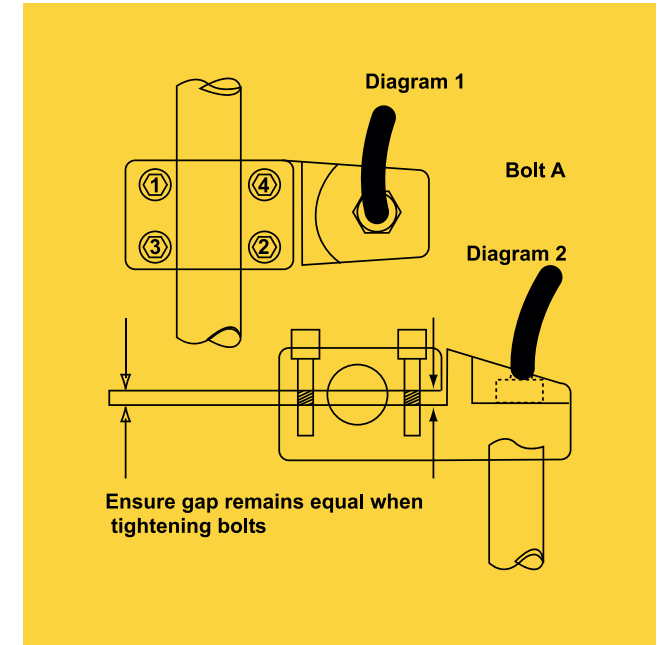

BIKE TYPE 3: RACE AND TOURING BIKES

- The ball of the foot should just reach the ground when you're sitting on the saddle and your feet, hands and bottom should each support around a third of your weight.
- Avoid potholes and keep the tyres pumped up hard. The wheels fitted to your sports bike will last as long as the ones fitted to any mountain bike.
- Long-distance touring machines are similar to sports bikes but have mudguards, luggage carriers and lower gears, perhaps with a triple chainset to cope with their different role.



Basic sports bikes are fitted with a gear lever on the frame. The gears are indexed, so change gear by clicking the lever up and down.



Some sports bikes do not have as wide a range of gears as on a mountain bike so the gear mechanisms may be more compact, with a shorter chain cage on the rear mech and a lighter front mech.



Top sports bikes and mountain bikes are fitted with clipless pedals, only usable with the correct shoes and cleats. Both the pedal and cleat must be kept clean to ensure that the device that binds the shoe to the pedal works reliably every time.



On top road bikes, the brake and gear levers are combined. To change up, you move the brake lever sideways. To change down, you operate the smaller lever. Keep the cable well lubricated with multipurpose lube but don't lube the shifter.

GUARANTEE NOTES:

ISSUE no. 2216rm

The guarantee is only valid provided that the cycle has been properly cared for and regularly serviced by a qualified dealer and has not been involved in any accident or been misused.

- I. This cycle is guaranteed against faulty manufacture as follows:
 - The mainframe on all cycles 18" wheel and over is guaranteed for lifetime use of the original owner. Cycles with 16" wheel or under have a 12-month warranty.
 - Front forks, pivot section frames and all other parts are guaranteed for 12 months, commencing the date on the purchase invoice, this applies to any size cycle.
 - Exceptions are tyres, tubes, brake shoes, control wires and handlebar grips, as these are items that with regular use would normally wear out within the guaranteed period.
- All claims must be made direct, with the supplying dealer, who will not be able to deal with any claim unless your claim is accompanied with:
 - The original purchase invoice.
 - Adequate proof that the bicycle has been properly serviced and cared for by an authorised dealer.
 - The guarantee is offered to the original purchaser and is not transferable.
- It is furthermore, the responsibility of the customer to ensure that the cycle is treated with respect.

Damage caused by neglect, lack of regular maintenance, racing, stunt riding, inappropriate use, abuse, accident or modification other than by an authorised dealer, is specifically excluded from the guarantee.

- The guarantee does not cover personal injuries, all riders should take out personal injury insurance to cover this. Damage to personal belongings or any costs incurred by the customer during the time that the cycle is off the road, or transport charges to or from the dealer in the event of the guarantee claim.
- Bending frames, forks, handlebars, seat-posts and rims are excluded from this warranty. Bending is a sign of abuse or punishment inconsistent with the bikes intended use, and therefore not covered under this limited warranty.
- The guarantee does not cover corrosion. Please be particularly aware of the risk of corrosion during the winter months caused by road salt.
- Under these terms, your supplying dealer will bear the cost of replacement parts. Labour charges will be borne by the purchaser.

! Warning: As with all mechanical components, the bicycle is subjected to wear and high stress. Different materials and components may react to wear or stress/fatigue in different ways. If the design life of a component has been exceeded, it may suddenly fail possibly causing injury to the rider. Any form of crack, scratches or change of colour in highly stressed areas indicates that the life of the component has been reached and it should be replaced.

Note: Rear mech (derailleur) hangers- bicycles with alloy frames, are often fitted with a separate detachable hanger. This component is designed to break if stressed so that damage to the frame is prevented.

Stress to this component will not be caused during normal riding. But as a result of accidental damage, pushing it out of alignment, and will therefore not be covered under warranty. Colour may fade in direct sunlight.

GENERAL MAINTENANCE:

Your bike should be taken back to your dealer (or serviced by yourself) for a check-up after about a month of light riding, 3 to 5 hours of hard off-road riding or about 10 to 15 hours of on-road use. If you think something is wrong with your bike, take it back to your dealer before riding again.

! Warning reference BMX and MTB bicycles (warning box): No bicycle is **INDESTRUCTIBLE**. Riders who race or take part in stunt riding, ramp jumping, acrobatics, or similar do so entirely at their own risk. BMX MTB'S are not guaranteed if used in competition racing of any description. As these cycles are regularly oiled and protection must be given to the chrome i.e., a spray lubricant film covering Vaseline, etc. As with all cycles, look after them and they will give reliable service. This applies especially to BMX and MTB.